

MEMBER  
**ABYC**  
Setting Standards for Safer Boating

23.1

TWENTY THREE  
POINT ONE  
ISO 9001

**BAYSTAR™**

**CAPILANO™**

**SEASTAR™**

# INSTALLATION INSTRUCTIONS

## AND OWNER'S MANUAL

[www.seastarsolutions.com](http://www.seastarsolutions.com)

*Now with  
positionable O-ring  
hose fittings*



# **SEASTAR™**

## **SEASTAR™ PRO** Classic Tilt Helms



*Before you do it your way,  
please try it our way*

# To the Installer and End User (Owner)

Thank you for choosing SeaStar Steering Systems by SeaStar Solutions. This Installation and Owner's Manual contains all the information that you and others will require for the safe installation and use of your steering system and MUST remain on board the boat. Throughout this manual, information for the safe installation and operation of the steering system will be distinguished in one of the following ways;

## WARNING

**Hazards or unsafe practices which could result in severe personal injury or death.**

Failure to adhere to a warning may lead to loss of steering control. Loss of steering control may result in unpredictable boat behavior, leading to ejection from boat causing property damage, personal injury and/or death.

## CAUTION

**Hazards or unsafe practices which could result in minor injury or product or property damage.**

## NOTICE

*Important information in regards to installation, use and maintenance of the steering components.*

## NOTICE

*Marine Canada Acquisition Inc. DBA SEASTAR SOLUTIONS is referred to as SeaStar Solutions throughout this publication.*

**These safety alerts alone cannot eliminate all of the hazards that may be present while on the water. SeaStar Solutions recommends that all users of the steering system take an accredited 'boating safety course', follow safe boating practices and are made aware of the environment that they will be in.**

# SAFETY INFORMATION

## WARNING

The safety information provided below is intended to inform you of the dangers that may be present before, during and after the installation. It is critical that you read and understand ALL the points noted.

The safe operation of the steering system is dependant upon proper installation and maintenance, common sense, safe judgment and the knowledge/expertise of the operator. Every installer/user of the steering system should know the following requirements 'before' installing/using the steering system.

If you have any questions regarding any of these warnings, contact SeaStar Solutions.

To reduce risk of severe injury or death. Always wear a Coast Guard Approved personal flotation device (PFD) and use an engine shut-off cord (lanyard).

## Before installation

1. Read and understand the Installation and Owner's Manuals provided with your steering components.
2. Ensure that all components required to complete the installation are on hand (including hoses, fittings, oil and the proper tools required for the installation).
3. SeaStar components are highly engineered and safety tested to ensure system integrity, DO NOT substitute any component with non-SeaStar components as this may compromise system performance/reliability.

## Installation

### CAUTION

**-3 helm pumps are fitted with positionable O-ring style hose fitting ports (referred throughout this manual as ORB). Do NOT attempt to install an NPT pipe fitting into a -3 helm hose fitting port. Doing so will lead to irreparable damage to the helm. ONLY use SeaStar Solutions O-ring style hose fittings (ORB).**

1. Install components as directed in all Installation Manuals (including helm pumps, hoses and fitting kits).
2. DO NOT modify or substitute any component in any way without written consent from SeaStar Solutions.
3. Comply with all system ratings/regulations (boat/engine, U.S.C.G.).
  - Cylinder MUST be compatible with engine(s) installed.
  - Cylinder MUST be rated for use on the engine(s) installed.
4. Confirm that there is no interference between the steering cylinder(s), tiebars and the transom, splashwell, outboard engine or jackplate or any combination of these parts by performing the following steps;
  - a) With engine fully tilted DOWN, turn steering wheel from hard over to hard over and confirm that no interference occurs.
    - if using a hydraulic jack plate the above must also be performed at all the positions of the jack plate.
  - b) Repeat step 4a) with engines tilted UP.
  - c) Perform step 4a) with each engine in DOWN/UP positions confirming that independent TRIM/TILT can be done without any interference.
5. Confirm that the steering cylinder can be fully stroked in both directions as well as full tilt and trim without stretching, chafing, rubbing and/or kinking of the hydraulic hoses.
6. Confirm that extruded nylon tubing has NOT been substituted for SeaStar Steering Hose.
7. DO NOT use a wire coil type trim switch with a hydraulic steering system as the wire can wind up tight around the steering wheel shaft and prevent further steering.
8. Conduct Oil Level and System Check as outlined in your Steering Cylinder and/or Power Assist Installation and Owner's Manual.

# Safety Information Continued

## WARNING

The safety information provided below is intended to inform you of the dangers that may be present before, during and after use. It is critical that you read and understand ALL the points noted.

### Prior to every use

1. Check Fluid level in highest helm pump. For oil level setting, consult your Installation and Owner's Manual shipped with your steering cylinder and/or SeaStar Power Assist Pump.
2. Verify immediate steering response when turning steering wheel(s). (Ensure engine turns when steering wheel is turned.)
3. Visually inspect all steering hoses and fittings for wear, kinking and/or leaks.
4. Check for binding, loose, worn or leaking steering components.

DO NOT OPERATE BOAT IF ANY COMPONENT IS NOT IN PROPER WORKING CONDITION.

### During use

1. WEAR A COAST GUARD-APPROVED PERSONAL FLOTATION DEVICE (PFD).
2. ATTACH ENGINE SHUT-OFF CORD (LANYARD) TO YOUR PFD.
3. Never allow anyone not familiar with the operation of the steering system operate the boat at any time.
4. Know and adhere to the operator restrictions for your area including;
  - Federal Laws/Regulations,
  - State Laws/Regulations and
  - Municipal Laws/Regulations.

DO NOT OPERATE BOAT IF ANY COMPONENT IS NOT IN PROPER WORKING CONDITION.

### After use

1. Rinse off steering system thoroughly using 'fresh, clean water only'.
  - Cleaning fluids containing ammonia, acids or any other corrosive ingredients **MUST NOT** be used for cleaning any part of the hydraulic steering system.

### Maintenance

1. Maintain steering system at a minimum of twice per year.
  - See Maintenance, on page 8 of this manual.

*Keep our waters clean for all current and future users. Dispose of ALL fluids in accordance with your local regulations.*

# INTRODUCTION

The SeaStar helms are the smoothest and most efficient hydraulic steering systems available. They have been designed for normal pleasure and commercial boat use where standard rigging arrangements are used.

Before proceeding with the installation, read these instructions thoroughly. Seastar Solutions cannot accept responsibility for installations where instructions have not been followed, where substitute parts have been used, or where modifications have been made to our products.

This precision built product may not function properly if dirt or contaminants are introduced into the system.

## NOTICE

*Due to a small amount of internal oil slip, a master spoke or centered steering wheel cannot be maintained with a hydraulic steering system. For best results, use an equal distance spoke steering wheel.*

## NOTICE

*Help protect your boating environment by ensuring that all used oil is disposed of properly.*

## Index

System Installation Overview.....	2
Mounting Template: Classic Tilt Helm .....	3
Mounting the Helm .....	5
Maintenance .....	8
Replacement Parts.....	9
Troubleshooting Guide .....	11
Technical Information .....	13
Statement of Limited Warranty .....	14
Return Goods Procedure .....	14

## Applicable Helms

HH6541-3, HH6542-3, HH6543-3, HH6544-3, HH6573-3 and HH6574-3.

# SYSTEM INSTALLATION OVERVIEW

---

## Step 1 Steering Cylinder installation:

Install your steering cylinder as per the Installation manual provided with your cylinder.

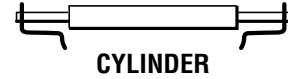

---

## Step 2 Tilt helm installation:

Install your Tilt Helm as per the detailed installation instructions on page 5 to page 7 of this manual.

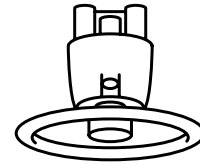

---

## Step 3 Filling and purging of Steering System:

Using the Fill and Purge instructions provided in your steering cylinder manual, fill and purge the steering system.

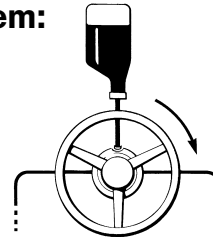

---

### NOTICE

*Power Assist/Liquid Tiebar applications, please refer to your Installation and Owner's Manual provided with your power assist/liquid tiebar valve for proper bleeding procedures.*

---

## Step 4 Oil level and system check:

Using the "Oil level and system checks" provided in your steering cylinder manual, confirm proper operation of your steering system.

---

### WARNING

**Oil Level and System Check is critical to the safe operation of your boat, failure to follow this important step may lead to loss of steering control resulting in property damage, personal injury and/or death.**

**Classic Tilt Helm  
 Mounting Template**

If printing of this page is required, please check measurements BEFORE you drill any holes to be sure that the template that you have printed is true and correct.

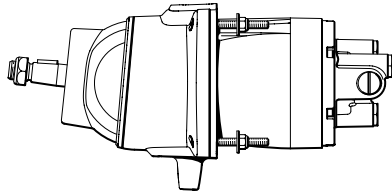

**HELM FLANGE OUTLINE**  
 5.16" x 5.3" (131 x 135 mm)  
 CORNER RADIUS 0.44" (11 mm)  
 (for reference only)

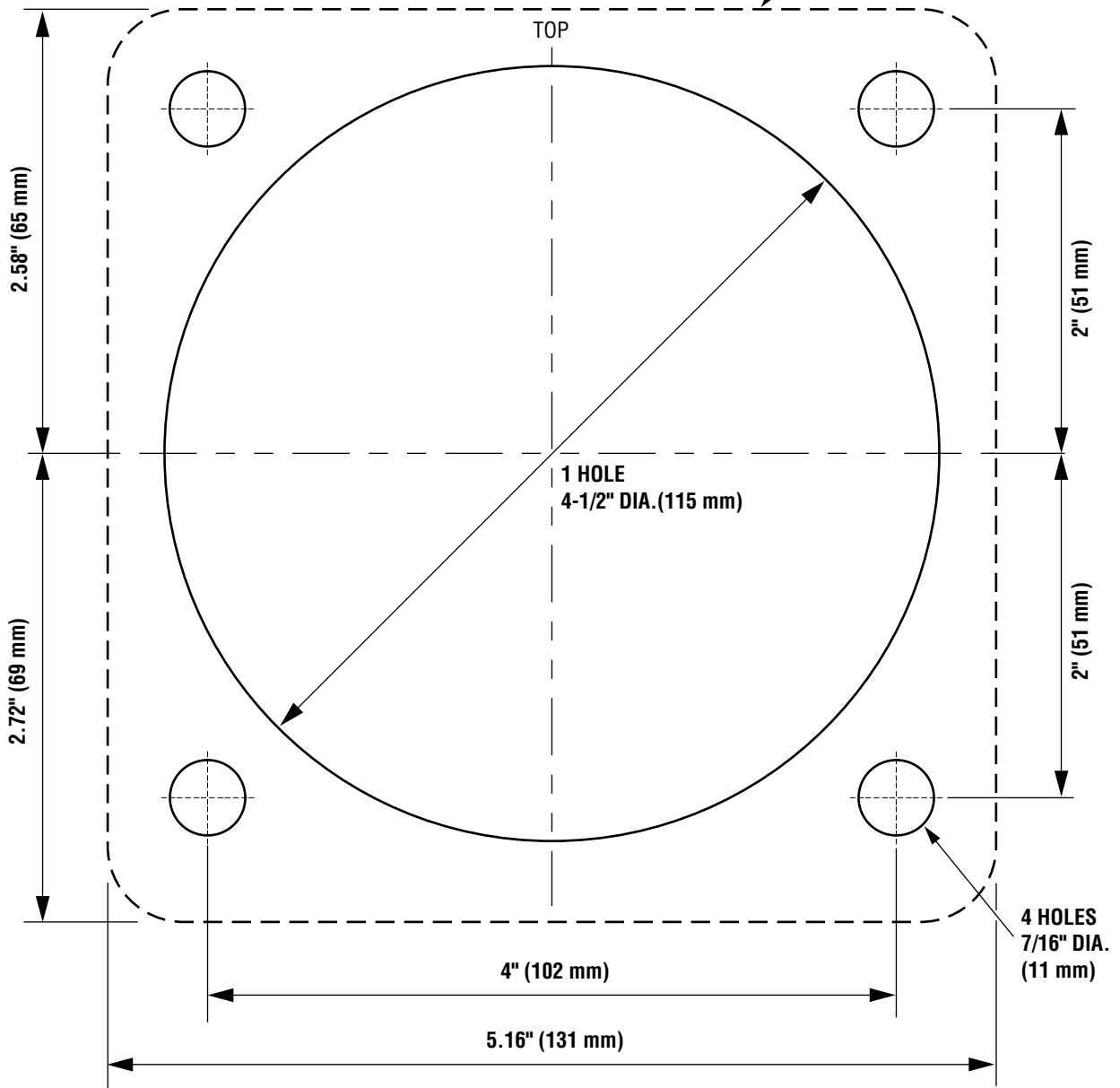

Figure 1. Mounting template.

*This page left intentionally blank.*



# MOUNTING THE HELM

## CAUTION

-3 helm pumps are fitted with positionable O-ring style hose fitting ports (referred throughout this manual as ORB). Do NOT attempt to install an NPT pipe fitting into a -3 helm hose fitting port. Doing so will lead to irreparable damage to the helm. ONLY use SeaStar Solutions O-ring style hose fittings (ORB).

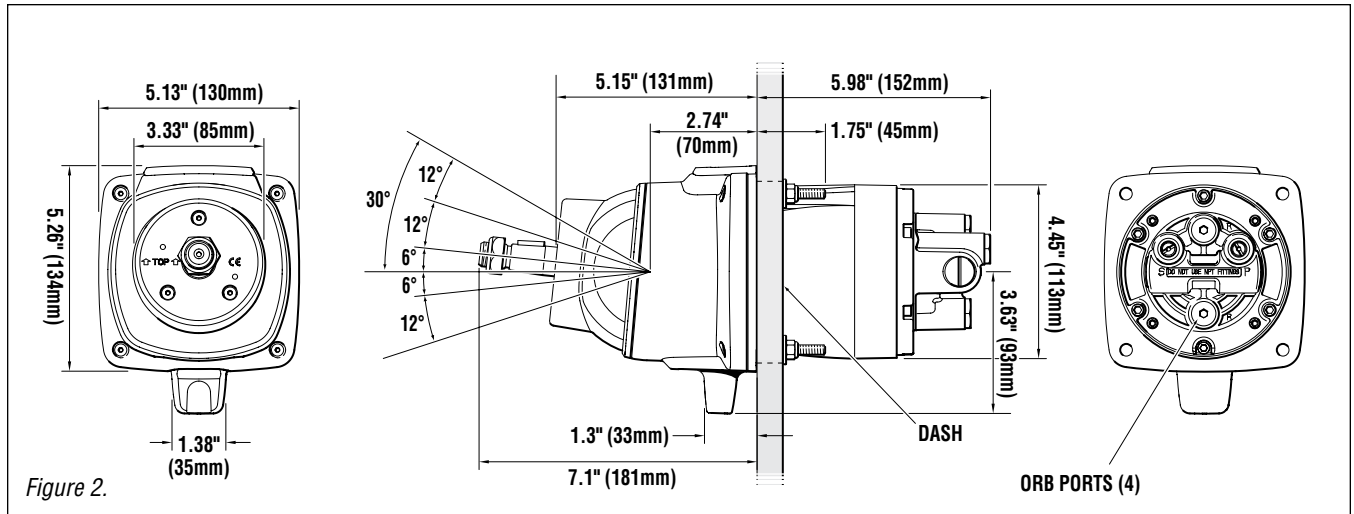

Figure 2.

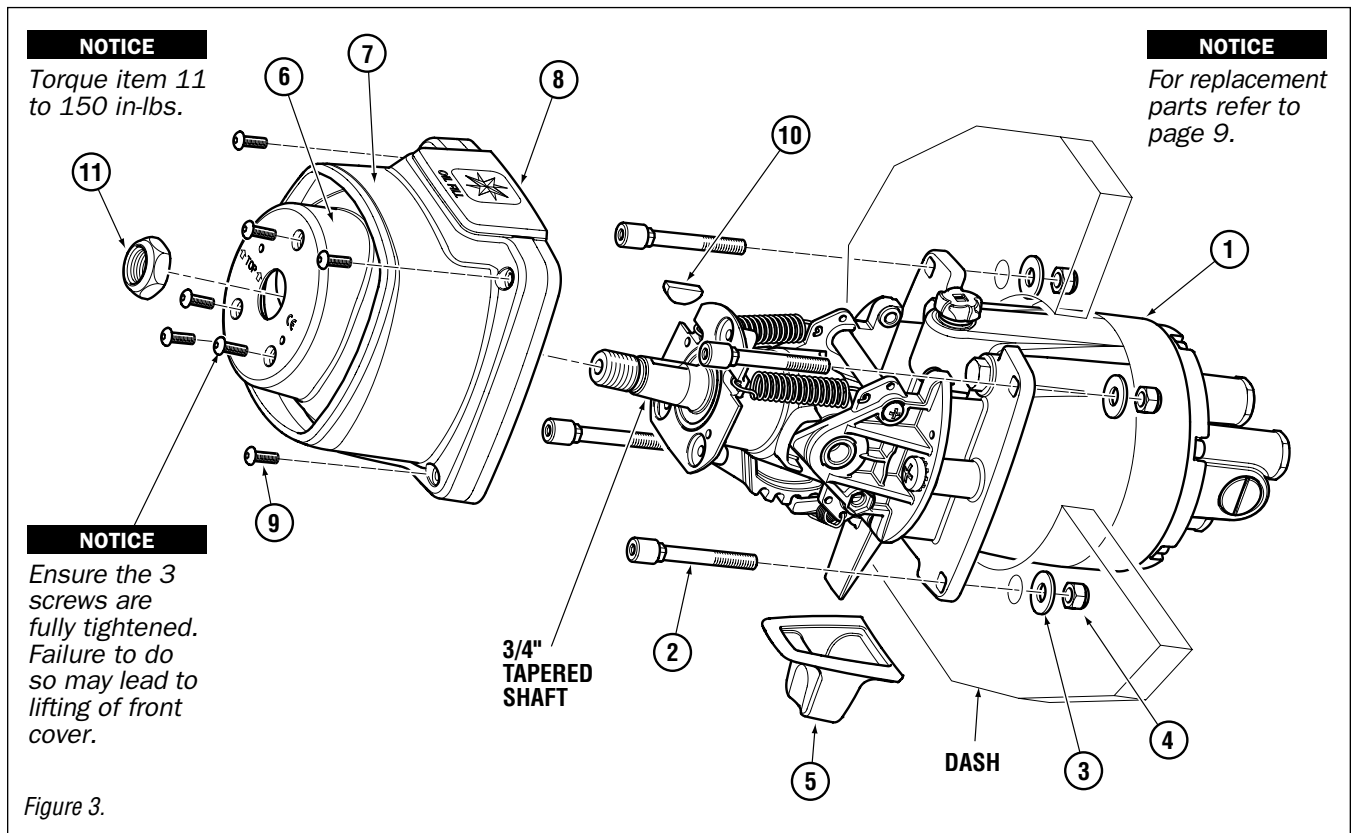

Figure 3.

ITEM	PART #	QTY	DESCRIPTION
1	Various	1	Classic Tilt Helm Pump
2	279086	4	Bolt, Dash, 1/4" x 20 UNC, SS
3	201429	4	Washer
4	067424	4	Nut, 1/4" NC Nyloc®
5	279050	1	Boot, Tilt Lever
6	279042	1	Cover, Front

ITEM	PART #	QTY	DESCRIPTION
7	279046	1	Cover, Rear
8	279048	1	Cover, Oil Fill
9	279082	7	Screw, BHSCS 8-32 x 1/2" SS
10	260130	1	Key, Woodruff
11	747521	1	Nut, Wheel Shaft

## Step 1 Helm position and drilling

- Using the template provided on page 3 of this manual select the appropriate position of your helm pump on the dash.
- BEFORE drilling, ensure that the position of the helm, when installed, will allow unrestricted operation of the steering wheel in ALL tilt positions and will not interfere with any other functional equipment on the inside and/or outside of the dash. (i.e. Throttle/shift levers, gauges, wiring, ABYC dash to steering wheel clearance requirements.)

### NOTICE

*Ensure there is adequate access to the filler port of the helm pump when installed.*

### NOTICE

*The helm pump may be mounted with the helm shaft horizontal, vertical or any angle in between.*

### NOTICE

*The helm pump filler port MUST be in the uppermost position.*

- Tape template to dash. (If template has been photocopied, it is suggested that you double check the measurements using a measuring device prior to any holes being drilled.)
- BEFORE drilling. Confirm that you will not be drilling into any wires or any other functional equipment that is located behind the dash.
- Drill the required center hole and appropriate helm mounting holes as shown on the template.

## Step 2 Mounting the helm pump to the dash

### WARNING

**Use ONLY the self-locking fasteners provided with your helm pump; substituting with non-self locking fasteners may lead to separation of steering equipment leading to loss of steering control and unpredictable boat behavior, which may result in person(s) being ejected from boat or collision with obstacle(s) causing property damage, personal injury and or death.**

1. Insert helm pump (item 1) through hole in dash.
2. Fasten helm to dash using the 4 x bolts (item 2) washers (item 3) and nut (item 4). DO NOT exceed 110 in/lbs (12Nm).
3. Fit tilt lever boot (item 5) to the lever on the tilt mechanism.
4. Fit the upper bezel (item 6) into the lower bezel (item 7) and position these two parts over the tilt mechanism and latch boot. Install the 7 x BHSCS 8-32 x 1/2" SS (item 9) screws into the positions shown.
5. Grease steering shaft with good quality marine grade grease.
6. Install the woodruff key (item 10) and wheel shaft nut (item 11), Tighten steering wheel shaft nut prior to continuing with installation instructions. Torque wheel shaft nut to 150 in/lb. **DO NOT** exceed 200 in/lb.

## Step 3 Tilt Operation Check

- Check tilt mechanism for proper operation. There are 5 positions available. Confirm that the tilt mechanism LOCKS in each position prior to operation of the steering system.

## Step 4 Re-Positionable Pump Fitting Installation (if required)

### ⚠ CAUTION

-3 helm pumps are fitted with positionable O-ring style hose fitting ports (referred throughout this manual as ORB). Do NOT attempt to install an NPT pipe fitting into a -3 helm hose fitting port. Doing so will lead to irreparable damage to the helm. ONLY use SeaStar Solutions O-ring style hose fittings (ORB).

### ⚠ WARNING

Failure to properly tighten the lock-nut (item 1) may lead to loss of steering control. Loss of steering control may result in unpredictable boat behavior, collision with an obstacle and/or ejection from vessel, leading to property damage, personal injury and/or death.

**NOTE: for straight ORB fittings simply torque fitting to 18 ft-lbs. Fitting re-orientation not required.**

1. Back off lock nut (item 1), counter-clockwise, until it stops.  
**NOTE: O-ring must be fully on sealing surface and cannot contact any threads. Do not use Teflon tape or any liquid pipe sealant with ORB fittings.**
2. Thread fitting into helm port until fitting washer (item 2) contacts the face of the helm port. Tighten hand tight. **DO NOT USE A WRENCH.**
3. Re-position fitting to desired orientation by turning it counter-clockwise to a MAXIMUM of 1 full turn.
4. While holding the fitting body securely with a wrench, torque the lock nut (item 1) to **18 ft-lbs.**
5. While holding the fitting body securely with a wrench, torque the hose end nut to **15 ft-lbs.**
6. Purge system per applicable instruction manual.

### ⚠ WARNING

SeaStar Solutions recommends that the hose and hose fittings are checked on a regular basis to ensure the safe operation of the steering system.

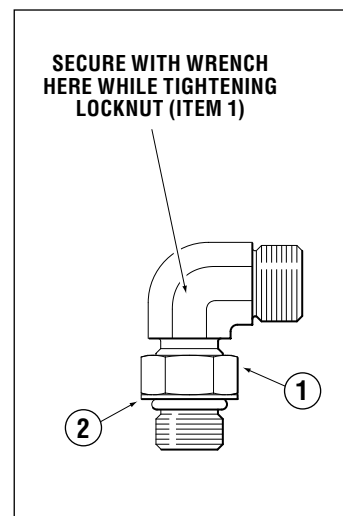

Figure 4.

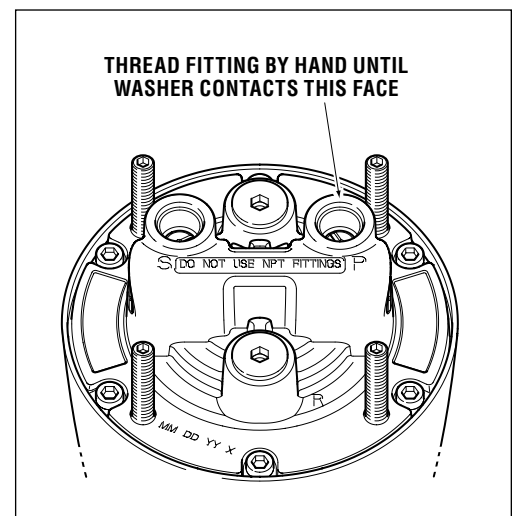

Figure 5.

## Step 5 Bleeding the Steering System

### NOTICE

Due to the many different styles of steering systems that these helms are used in, it is suggested that you refer to the installation manual included with your 'Steering Cylinder', or, contact SeaStar Solutions for proper bleeding procedures.

# MAINTENANCE

Following the routine maintenance schedules noted below, in the time frame noted will ensure years of great service of your SeaStar Steering System, as well as keep you and your passengers safe from the dangers that are present on the water. Always refer to ALL installation manuals provided with your helm, cylinders and any other part of your steering system for a complete list of routine maintenance procedures. If you are instructed to consult with ANY manual that you may not have, please contact SeaStar Solutions for the proper manual.

---

## Every trip, prior to engine start up and/or launch

- Check fluid level in helm pump (consult your steering cylinder installation manual for proper oil level setting)
- Hoses – Ensure hoses are in good condition and free of wear, kinks or any other signs of damage. If hose/tube shows signs of wear, they MUST be replaced prior to operation.
- Turn steering wheel(s) hard over to hard over to ensure engine(s), rudder(s) and/or outdrive(s) are responding to input from the wheel. If vessel is fitted with multiple steering stations, check ALL wheels and autopilot if equipped.

---

## Every 100 hours or 3 months (whichever comes first)

- All points noted in Step #1
- Check torque setting on ALL fasteners throughout the steering system. Refer to page 13 for torque specifications and tighten as required.

---

## Every 6 months

- ALL points noted in Steps #1 and #2
- Remove steering wheel from helm pump. Clean wheel shaft and apply a good quality marine grease. Reinstall steering wheel and wheel shaft nut, torque to 150 in/lbs.
- Check torque on ORB hose fitting locknuts.

---

## NOTICE

*Ensure wheel shaft nut is tightened as per torque setting on page 5.*

---

## WARNING

**Failure to comply with the maintenance checks as noted above may result in loss of steering control and unpredictable boat behavior, which may result in person(s) being ejected from the boat or collision with obstacle(s) causing property damage, personal injury and/or death.**

# REPLACEMENT PARTS

## Classic Tilt Helms

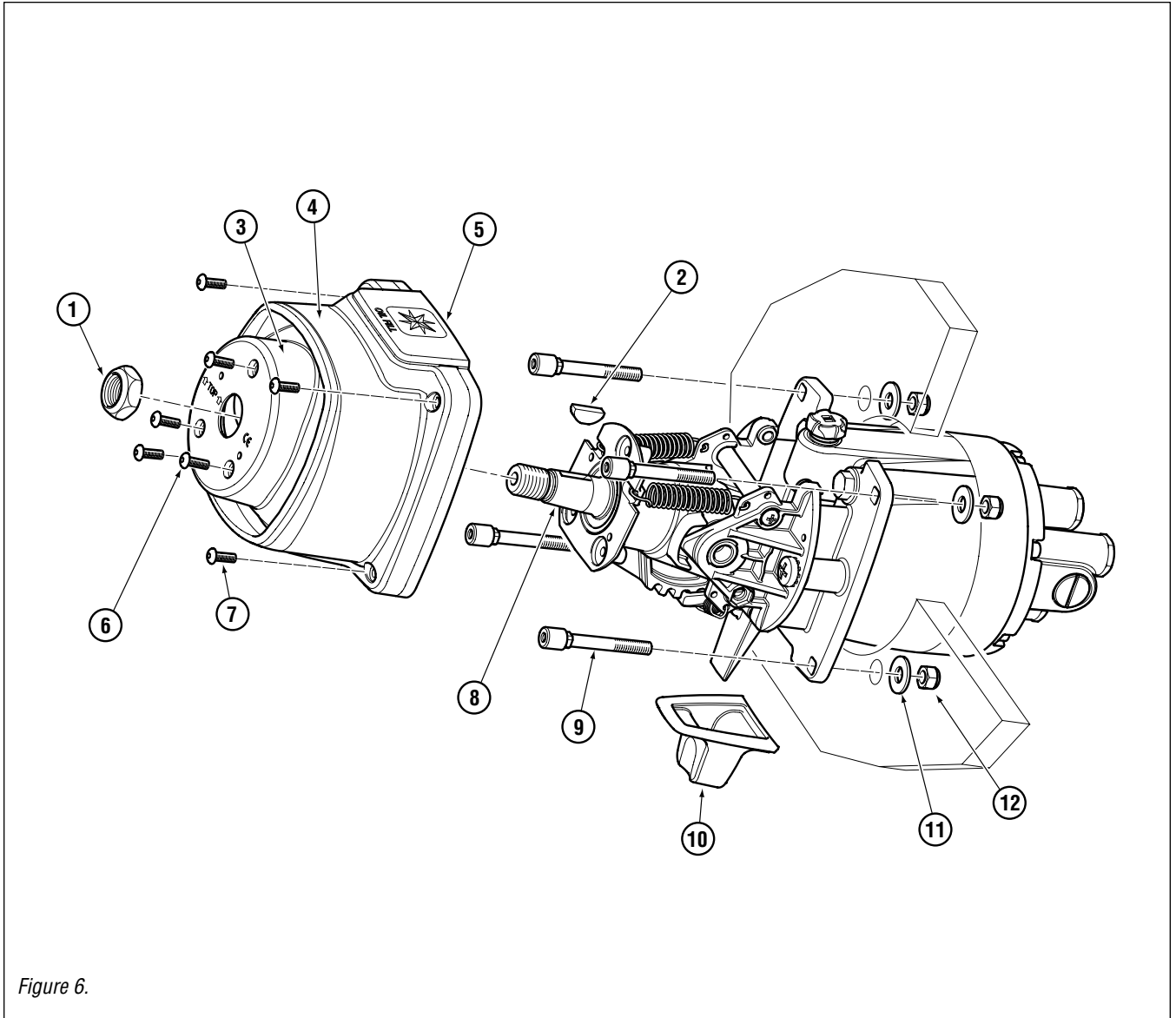

Figure 6.

### SHAFT SEAL KIT # HP6032

ITEM	QTY. IN KIT	NOTE
1	1	Includes Shaft Seal
2	1	Includes Shaft Seal

### TILT MECHANISM KIT # HA6523

ITEM	QTY. IN KIT	NOTE
3	1	Not available individually
4	1	Not available individually
5	1	Not available individually
6	7	Not available individually
7	1	Not available individually
8	1	Not available individually
9	1	Not available individually
10	1	Not available individually
11	4	Not available individually
12	4	Not available individually

*This page left intentionally blank.*

# TROUBLESHOOTING GUIDE

<b>FAULT</b>	<b>CAUSE</b>	<b>SOLUTION</b>
<b>1. Cannot get helm shaft to go into U-Joint.</b>	<ul style="list-style-type: none"><li>• U-Joint bolt is too tight.</li></ul>	<ul style="list-style-type: none"><li>• Loosen the “Top” bolt no more than 1/4” to allow the Helm shaft to be installed.</li></ul>
<b>2. Tilt will not lock into place.</b>	<ul style="list-style-type: none"><li>• Spring has come undone. Or a broken Tilt tooth.</li></ul>	<ul style="list-style-type: none"><li>• Re-attach spring. Replace Tilt mechanism.</li></ul>
<b>3. Wheel is really hard to turn in both directions.</b>	<ul style="list-style-type: none"><li>• Tilt boot is rubbing on the steering wheel hub.</li></ul>	<ul style="list-style-type: none"><li>• Confirm that the rubber boot is installed over both lips and is NOT rubbing on the wheel hub.</li></ul>
<b>4. Cannot remove steering wheel.</b>	<ul style="list-style-type: none"><li>• Seized in place. No grease applied to shaft before wheel installation.</li></ul>	<ul style="list-style-type: none"><li>• Using your knee under the wheel and your hand on top, with the wheel shaft nut installed one turn on shaft, lightly tap helm shaft to release wheel.</li></ul>
<b>5. During filling, helm becomes completely jammed.</b>	<ul style="list-style-type: none"><li>• Blockage in the line between the helm(s) and cylinder(s).</li><li>• PRO helm used with an unbalanced cylinder.</li><li>• Tilt mechanism to helm pump wheel shaft nut, NOT installed properly.</li></ul>	<ul style="list-style-type: none"><li>• Make certain hose/tubing has not collapsed during installation.</li><li>• DO NOT use ANY PRO helm pump with ANY un-balanced cylinder.</li><li>• Tighten and torque nut.</li></ul>
<b>6. System is very difficult to fill. Air keeps burping out top of helm, even after system appears full.</b>	<ul style="list-style-type: none"><li>• System is not being bled properly/completely.</li><li>• Cylinder is mounted upside down, trapping air in cylinder body.</li></ul>	<ul style="list-style-type: none"><li>• Consult with your cylinder installation manual for proper bleeding. If boat is fitted with an autopilot, ensure the a/p pump is jogged back and fourth for several seconds during the bleeding procedure.</li><li>• Install cylinder with bleed fittings pointing UP. If unable to mount cylinder in this position, you MUST disconnect cylinder, bleed system, then reinstall.</li></ul>

---

**7. Steering is stiff and hard to turn, even when the vessel is not moving.**

- Mechanical binding of rudder(s), outboard engine(s), or outdrive(s).
- Restrictions in hose/tube.
- Air in system.
- Wrong fluid has been used.

- Ensure rudder(s), outboard(s) or sterndrive(s) move freely with cylinder disconnected.
- See fault 1.
- See fault 2.
- Only use SeaStar Steering Fluid.

---

**8. One helm unit is very bumpy and requires too many turns hard over to hard over.**

- Debris in inlet check of helm pump.

- Contact Authorized repair facility, or, replace helm pump.

---

**9. Steering is easy to turn at the dock, but, becomes hard to turn when underway.**

- Steering wheel is too small.
- Cylinder doesn't provide enough force to turn rudder(s).
- Incorrectly set, or adjusted torque tab.
- Mechanical interference.

- Install larger wheel (MAX 28").
- Confirm cylinder installed is that for the boat.
- Re-adjust torque tab.
- See fault 3.

---

**10. Turning one wheel causes the other wheel to turn on its own.**

- Debris in the inlet checks of the helm pump that is turning on its own.

- Contact Authorized repair facility, or, replace helm pump.



# TECHNICAL INFORMATION

## WARNING

Failure to adhere to the torque specifications below may lead to separation of components resulting in loss of steering control causing ejection from vessel, or collision with obstacles, leading to property damage, personal injury and/or death.

## Bolt Torque Specifications

Values are stated in: **in/lbs (N.m)**

Bolt Size	18-8SS	Brass
2-56	2.5 (.282)	2.0 (.226)
2-64	3.0 (.338)	2.5 (.282)
3-48	3.9 (.440)	3.2 (.361)
3-56	4.4 (.497)	3.6 (.407)
4-40	5.2 (.587)	4.3 (.486)
4-48	6.6 (.740)	5.4 (.610)
5-40	7.7 (.869)	6.3 (.712)
5-44	9.4 (1.06)	7.7 (.869)

These are the recommended maximum torque values for reusable dry bolts. Bolts should be torqued to this value +0% -20%. For lubricated bolts, multiply the dry bolt torque values by .75.

Bolt Size	18-8SS	Brass	Bolt Size	18-8SS	Brass
6-32	9.6 (1.08)	4.9 (.554)	5/16"-18	132.0 (14.91)	107.0 (12.10)
6-40	12.0 (1.35)	9.9 (1.12)	5/16"-24	142.0 (16.04)	116.0 (13.11)
8-32	20.0 (2.25)	16.0 (1.81)	3/8"-16	236.0 (26.66)	192.0 (21.71)
8-36	22.0 (2.48)	18.0 (2.03)	3/8"-24	259.0 (29.20)	212.0 (23.97)
10-24	23.0 (2.59)	19.0 (2.14)			
10-32	32.0 (3.61)	26.0 (2.94)			
1/4"-20	75.0 (8.47)	62.0 (7.01)			
1/4"-28	94.0 (10.6)	77.0 (8.70)			

Values are stated in: **ft/lbs (N.m)**

Bolt Size	18-8SS	Brass
7/16"-14	31.0 (42.00)	26.0 (35.25)
7/16"-20	33.0 (44.74)	27.0 (36.61)
1/2"-13	43.0 (58.30)	35.0 (47.45)
1/2"-20	45.0 (61.01)	37.0 (50.17)
9/16"-12	57.0 (77.28)	47.0 (63.72)
9/16"-18	63.0 (85.42)	51.0 (69.15)

Bolt Size	18-8SS	Brass	Bolt Size	18-8SS	Brass
5/8"-11	93.0 (126.09)	76.0 (103.04)	1"-8	287.0 (389.12)	235.0 (318.62)
5/8"-18	104.0 (141.00)	85.0 (115.24)	1"-14	259.0 (351.16)	212.0 (287.43)
3/4"-10	128.0 (173.55)	104.0 (141.00)			
3/4"-16	124.0 (168.12)	102.0 (138.29)			
7/8"-9	194.0 (236.03)	159.0 (215.58)			
7/8"-14	193.0 (261.67)	158.0 (214.22)			

## Helm Pump

	DISPLACEMENT	RELIEF VALVE	PORTS*
HH6541-3	1.7 cu. in. (27.8 cc)	1000 PSI (68 Bar)	-5 ORB
HH6542-3	2.4 cu. in. (39.3 cc)	1000 PSI (68 Bar)	-5 ORB
HH6543-3	2.0 cu. in. (33.0 cc)	1000 PSI (68 Bar)	-5 ORB
HH6544-3	1.4 cu. in. (22.9 cc)	1000 PSI (68 Bar)	-5 ORB
HH6573-3	1.7 cu. in. (27.8 cc)	1500 PSI (102 Bar)	-5 ORB
HH6574-3	2.0 cu. in. (33.0 cc)	1500 PSI (102 Bar)	-5 ORB

\*Helm fill/vent port is a 1/4" NPT port.

## Helm Pump Shaft

	TAPER	THREAD	KEY SIZE
All	3/4" Standard, 1" per ft.	5/8" NF	3/16"

# Statement of Limited Warranty

We warrant to the original retail purchaser that **Marine Canada Acquisition Inc. DBA SEASTAR SOLUTIONS** (herein forward referred to as **SeaStar Solutions**) products have been manufactured free from defects in materials and workmanship. This warranty is effective for two years from date of purchase, excepting that where **SeaStar Solutions** products are used commercially or in any rental or income producing activity, then this warranty is limited to one year from the date of purchase.

We will provide replacement product without charge, for any **SeaStar Solutions** product meeting this warranty, which is returned (freight prepaid) within the warranty period to the dealer from whom such product were purchased, or to us at the appropriate address. In such a case **SeaStar Solutions** products found to be defective and covered by this warranty, will be replaced at **SeaStar Solutions'** option, and returned to the customer.

The above quoted statement is an extract from the complete **SeaStar Solutions** products warranty statement. A complete warranty policy is available in our **SeaStar Solutions** products catalogue.

## Return Goods Procedure

Prior to returning product to **SeaStar Solutions** under warranty, please obtain a *Return Goods Authorization number* (claim number).

Be sure to label the goods with:

- a) the name and address of the sender, and
- b) the return goods authorization number (claim number)

Please address the returned goods as follows:

**From U.S.A.**

RGA # ?  
SeaStar Solutions  
c/o UPS-SCS  
19308 70th Ave S.  
Kent, WA 98032

**From Canada**

RGA # ?  
SeaStar Solutions  
3831 No. 6 Road  
Richmond, B.C.  
Canada V6V 1P6

---

### Technical Support

Phone: 604-248-3858

email: [seastar@seastarsolutions.com](mailto:seastar@seastarsolutions.com)

Hours: Monday - Friday 05:00 – 15:30 PST

Web: [www.seastarsolutions.com](http://www.seastarsolutions.com)



**SEASTAR  
SOLUTIONS®**

SEASTAR SOLUTIONS  
3831 NO.6 ROAD  
RICHMOND, B.C.  
CANADA V6V 1P6

FAX 604-270-7172

**[www.seastarsolutions.com](http://www.seastarsolutions.com)**

**ISO 10592**



FORM NO. 998004 Rev. D

© 2014 MARINE CANADA ACQUISITION INC.  
DBA SEASTAR SOLUTIONS

PRINTED IN CANADA

2000-02/16